

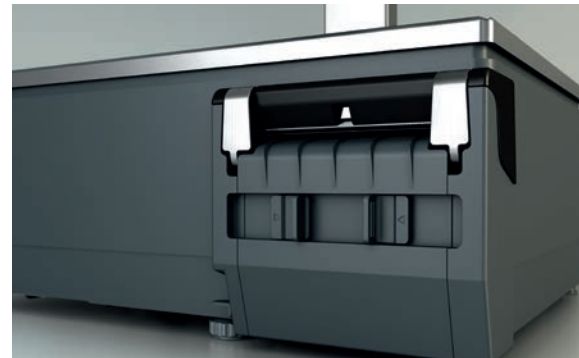

X-CLASS GETTING INTO THE FUTURE

X-CLASS LESS IS MORE



THE LATEST COMPUTER TECHNOLOGY IN A COMPACT DESIGN TEAMED WITH AN 'ALL-PURPOSE' PRINTER. THE XC LINE REPRESENTS ACCESS TO HIGH-PERFORMANCE PC-BASED SCALES WITH TOUCHSCREEN OPERATION. COMFORTABLE, INTUITIVE AND EASY TO WORK WITH.

HIGHLIGHTS

- Open PC-based scale with high-speed Intel Dual Core processor for optimum performance and smooth graphics
- Use of a quick, reliable and energy-saving mass storage device (SSD)
- Based on the latest operating systems: Windows 7 or Linux
- Easy Load printer (for tickets, labels and linerless operation with paper roll widths of up to 80 mm for easy roll replacement)
- Easy Clean housing surface for ease of cleaning and problem-free removal of stray labels
- Frameless Displays for maximum cleaning efficiency
- Optional tilt compensation (Accurate weighing results even when the scale is not leveled)



BIZERBA X-CLASS

The Bizerba XC line of scales combines all essential retail activities: weighing, transaction handling, printing and providing advice as well as displaying promotional messages and cross-selling opportunities. The open PC platform offers sufficient capacity to cope with new features or individual customer requirements in the future. Even the use of 3rd-party software presents no problems.

The 'all-purpose' printer is unique to the market and can perform every conceivable printing task that can be required of a weighing device. Furthermore, replacing the paper roll is a very brief and intuitive process, and daily cleaning of the scale can be carried out quickly and easily. This is supported by each scale's compact design, the easy clean surface of the housing and the newly developed, frameless Easy Clean display.

SOFTWARE

.RetailApps are true masters in flexibility, adapting to meet specific customer requirements. An individual .RetailApp is developed for each customer need and simply connected to the .RetailPowerScale scale software via standardized docking interfaces. That saves valuable development time and money, plus it provides investment security in terms of servicing and maintenance.

MEMBER OF THE BIZERBA GROUP

Bizerba GmbH & Co. KG
Wilhelm-Kraut-Straße 65
72336 Balingen
Germany

Tel: +49 7433 12-0
Fax: +49 7433 12-2696
marketing@bizerba.com

www.bizerba.com

The publisher accepts no liability for printing errors or color variations as a result of image quality or the printing process, and reserves the right to make structural or technical modifications.

Access to the future. The latest computer technology in a compact design teamed with an 'all-purpose' printer. The XC represents affordable access to high-performance PC-based scales with touchscreen operation. Comfortable, intuitive and easy to work with.



More information
High performance
with a wide range of
solutions and options.

Product Description

The Bizerba XC 100 counter scale combines all essential retail activities: weighing, transaction handling, printing and providing advice as well as displaying promotional messages and cross selling.

The open PC platform offers sufficient capacity to cope with new features or customer-specific requirements in the future. Even the use of 3rd-party software presents no problems. The 'all-purpose' printer is unique to the market and can perform every conceivable printing task that can be required of a weighing device. Furthermore, replacing the paper roll is a very brief and intuitive process, and daily cleaning of the scale can be carried out quickly and easily. This is supported by each scale's compact design, the easy clean surface of the housing and the newly developed, frameless easy clean display.



XC 100

Highlights

- Easy clean for quick and easy cleaning of the scale
 - surface: problem free removal of stray labels
 - displays: frameless for maximum cleaning efficiency
 - load plate: optimum ease of handling
- Easy load enables paper rolls to be changed in a matter of seconds
 - 'all-purpose' printer with ticket and linerless operation up to 80 mm paper roll widths
 - Additional label layout possible on pre-printed linerless paper
- Label printer*
 - 'Paper near end' function*
(alert when almost out of paper for unattended scales in self-service use)
- Easy level tilt compensation*
 - Accurate weighing results even when the scale is not leveled, no loss of revenue
- High-end PC-based scale with outstanding Intel® Dual Core processor for optimum performance and perfect graphics with minimum power consumption
- High-end software package .Retail Framework
 - .RetailPowerScale scale software
 - .RetailApps for additional functionality*
 - .RetailIntegratorsKit (RIK) for 3rd-party software*

Plus many more software options for additional solutions.



Easy load printer



Easy clean load plate

* Options

- Easy level tilt compensation
- Various weighing ranges
- Cash drawer
- 'Paper near end' function (alert when almost out of paper)
- WLAN

Members of the Bizerba Group

Bizerba GmbH & Co. KG
Wilhelm-Kraut-Straße 65
72336 Balingen
Deutschland
Tel. +49 7433 12-0
Fax +49 7433 12-2696
marketing@bizerba.com
www.bizerba.com

Access to the future. The latest computer technology in a compact design teamed with an 'all-purpose' printer. The XC represents affordable access to high-performance PC-based scales with touchscreen operation. Comfortable, intuitive and easy to work with.



More information
High performance
with a wide range of
solutions and options.

Specifications	Facts	Details
Color	Anthracite grey	RAL 7016
Operator display	10,1" Touch TFT	Resolution: 1024 x 600 (WSVGA) LED backlight 5-wire resistive touch technology Angle stepless adjustable
Customer display	7" TFT	Resolution: 800 x 480 Pixel LED backlight
Operating system	POSReady BizLPOS	Windows Linux
Scale software	.RetailPowerScale RIK (.Retail Integrators Kit)	Bizerba scale software compatible with .Retail Framework products 3rd-party software (OEM)
Processor	Intel® Atom™ Processor N2800 Dual Core	1.86 GHz frequency L2-Cache: 1MB Instruction set: 64-bit Mini-ITX form factor Integrated graphics card (clock speed 640 MHz)
RAM	DDR3	2 GB RAM
Mass storage	SSD	32 GB
Printer	3-in-1 (Label, ticket or linerless)	optional 2" or 3" Paper width up to 3" (80 mm) Clamshell model (for easy change of paper rolls) Print speed up to 100 mm/s
Interfaces	2 x USB 3.0 2 x USB 2.0 1 x COM RS 232 RJ-45 Audio port	Superspeed Highspeed DSUB RS 232 RJ-45, GBit LAN 3,5 mm jack
Weighing ranges	3/6 kg 6/15 kg	Scale division 1/2 g, Min. 20 g Scale division 2/5 g, Min. 40 g
Temperature range	-10 °C to +40 °C	
Power consumption	with 230 V max. 250 mA with 120 V max. 350 mA	
Weight	XC 100	app. 10 kg

Options	Facts	Details
Software add-ons	<ul style="list-style-type: none"> - .RetailApps - cash register, scanning, e-cash, inventory, delivery note, proof of country of origin, time registration, video journal, .RetailConnect 	<ul style="list-style-type: none"> - Extra software functions via .Retail Apps - Extra software functions via modules
Easy Level	Tilt compensation	Automatic adjustment of incorrect weighing even when the scale is not leveled
WLAN modules	BWLC USB	Bizerba Wireless LAN Client 802.11 a/b/g max. 54 MBit/s USB WLAN Stick (Not possible in system networks) 802.11 a/b/g/n max. 300 MBit/s
Licenses for software modules	proof of country of origin, cash register, scanning, e-cash, staff time recording, inventory/re-weighing/returns, delivery note, returns/cash invoice/purchase order	
Connection of cash drawer	Cash draw connection (COM)	RJ 12

XC 100



Symbols



Intel Logo

Core 2 Duo
Chipn

Linux

Windows
Logo

Dimensions

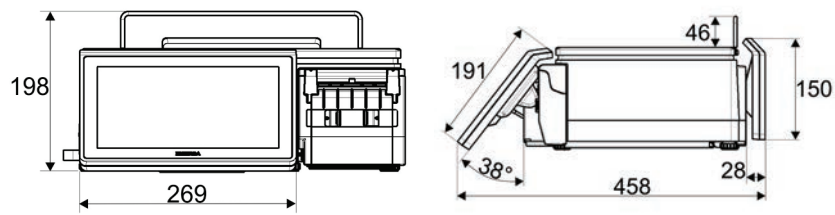

Members of the Bizerba Group

Bizerba GmbH & Co. KG
Wilhelm-Kraut-Straße 65
72336 Balingen
Deutschland
Tel. +49 7433 12-0
Fax +49 7433 12-2696
marketing@bizerba.com
www.bizerba.com

Access to the future. The latest computer technology in a compact design teamed with an 'all-purpose' printer. The XC represents affordable access to high-performance PC-based scales with touchscreen operation. Comfortable, intuitive and easy to work with.



More information
High performance
with a wide range of
solutions and options.

Product Description

The Bizerba XC 800 counter scale combines all essential retail activities: weighing, transaction handling, printing and providing advice as well as displaying promotional messages and cross selling. Therefore, the XC 800 is excellently suited for fresh counters. It is ideal in support of proactively offering advice to customers. When combined with a cash drawer, it can also be used as a high-performance checkout solution.

The open PC platform offers sufficient capacity to cope with new features or customer-specific requirements in the future. Even the use of 3rd-party software presents no problems. The 'all-purpose' printer is unique to the market and can perform every conceivable printing task that can be required of a weighing device. Furthermore, replacing the paper roll is a very brief and intuitive process, and daily cleaning of the scale can be carried out quickly and easily. This is supported by each scale's compact design, the easy clean surface of the housing and the newly developed, frameless easy clean display.



XC 800

Highlights

- Easy clean for quick and easy cleaning of the scale
 - surface: problem free removal of stray labels
 - displays: frameless for maximum cleaning efficiency
 - load plate: optimum ease of handling
- Easy load enables paper rolls to be changed in a matter of seconds
 - 'all-purpose' printer with ticket and linerless operation up to 80 mm paper roll widths
 - Additional label layout possible on pre-printed linerless paper
- Label printer*
 - 'Paper near end' function*
(alert when almost out of paper for unattended scales in self-service use)
- Easy level tilt compensation*
 - Accurate weighing results even when the scale is not leveled, no loss of revenue
- High-end PC-based scale with outstanding Intel® Dual Core processor for optimum performance and perfect graphics with minimum power consumption
- High-end software package .Retail Framework
 - .RetailPowerScale scale software
 - .RetailApps for additional functionality*
 - .RetailIntegratorsKit (RIK) for 3rd-party software*

Plus many more software options for additional solutions.



Easy load printer



Easy clean load plate

* Options

- Easy level tilt compensation
- Various weighing ranges
- Cash drawer
- 'Paper near end' function (alert when almost out of paper)
- WLAN
- EC-Cash interface

Members of the Bizerba Group

Bizerba GmbH & Co. KG
Wilhelm-Kraut-Straße 65
72336 Balingen
Deutschland
Tel. +49 7433 12-0
Fax +49 7433 12-2696
marketing@bizerba.com
www.bizerba.com

Access to the future. The latest computer technology in a compact design teamed with an 'all-purpose' printer. The XC represents affordable access to high-performance PC-based scales with touchscreen operation. Comfortable, intuitive and easy to work with.



More information
High performance
with a wide range of
solutions and options.

Specifications	Facts	Details
Color	Anthracite grey	RAL 7016
Operator display	10,1" Touch TFT	Resolution: 1024 x 600 (WSVGA) LED backlight 5-wire resistive touch technology Angle stepless adjustable
Customer display	7" TFT	Resolution: 800 x 480 Pixel LED backlight
Operating system	POSReady BizLPOS	Windows Linux
Scale software	.RetailPowerScale RIK (.Retail Integrators Kit)	Bizerba scale software compatible with .Retail Framework products 3rd-party software
Processor	Intel® Atom™ Processor N2800 Dual Core	1.86 GHz frequency L2-Cache: 1MB Instruction set: 64-bit Mini-ITX form factor Integrated graphics card (clock speed 640 MHz)
RAM	DDR3	2 GB RAM
Mass storage	SSD	32 GB
Printer	3-in-1 (Label, ticket or linerless)	optional 2" or 3" Paper width up to 3" (80 mm) Clamshell model (for easy change of paper rolls) Print speed up to 100 mm/s
Interfaces	2 x USB 3.0 2 x USB 2.0 1 x COM RS 232 RJ-45 Audio port	Superspeed Highspeed DSUB RS 232 RJ-45, GBit LAN 3,5 mm jack
Weighing ranges	3/6 kg 6/15 kg	Scale division 1/2 g, Min. 20 g Scale division 2/5 g, Min. 40 g
Temperature range	-10 °C to +40 °C	
Power consumption	with 230 V max. 250 mA with 120 V max. 350 mA	
Weight	XC 800	app. 10 kg

Options	Facts	Details
Software add-ons	cash register, scanning, e-cash, inventory, delivery note, proof of country of origin, time registration, video journal, .RetailConnect	- Extra software functions via .Retail Apps - Extra software functions via modules
Easy Level	Tilt compensation	Automatic adjustment of incorrect weighing even when the scale is not leveled
WLAN modules	BWLC USB	Bizerba Wireless LAN Client 802.11 a/b/g max. 54 MBit/s USB WLAN Stick (Kein Durchbedienen möglich) 802.11 a/b/g/n max. 300 MBit/s
Licenses for software modules	proof of country of origin, cash register, scanning, e-cash, staff time recording, inventory/re-weighing/returns, delivery note, returns/cash invoice/purchase order	
Connection of cash drawer	Cash draw connection (COM)	RJ 12

XC 800



Symbols



Intel Logo

Core 2 Duo
Chip

Linux

Windows
Logo

Dimensions

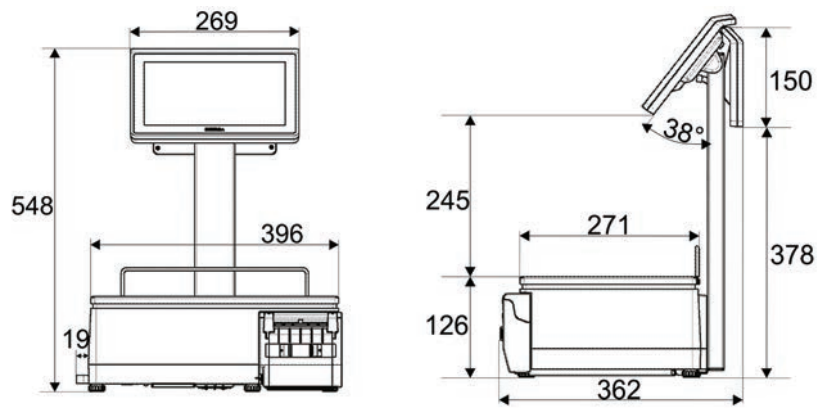

Members of the Bizerba Group

Bizerba GmbH & Co. KG
Wilhelm-Kraut-Straße 65
72336 Balingen
Deutschland
Tel. +49 7433 12-0
Fax +49 7433 12-2696
marketing@bizerba.com
www.bizerba.com