

**BIZERBA**

\_balanced information

III/132e



**BIZERBA | AUTOMATIC PRECISION**

# SLICING MACHINE VS 12 D



→ UNIVERSAL PRECISION SLICING  
MACHINE.



→ ERGONOMICALLY PERFECT  
SLIDE CONSTRUCTION

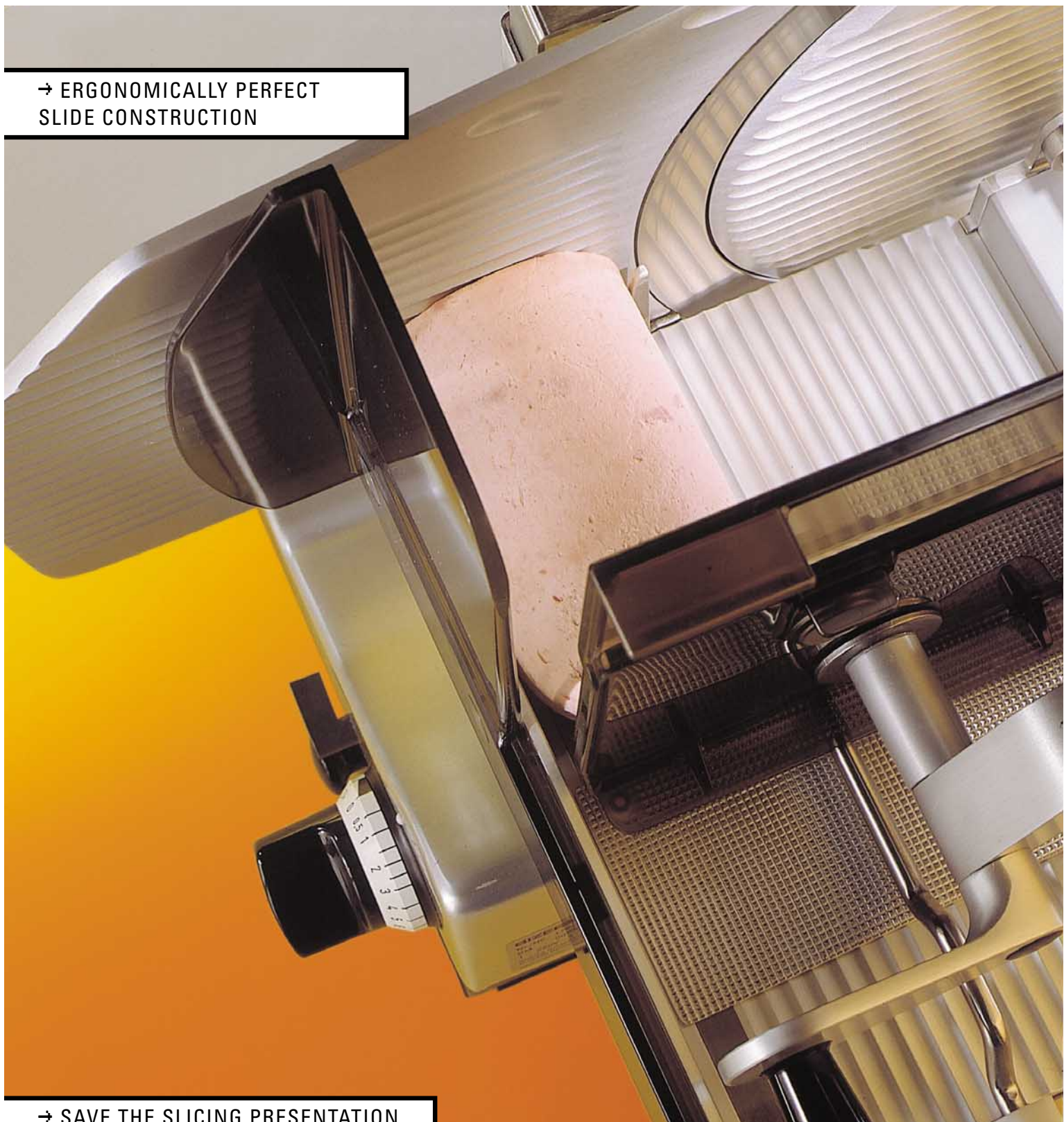

→ SAVE THE SLICING PRESENTATION  
SIMPLY BY PRESSING THE "SET" KEY

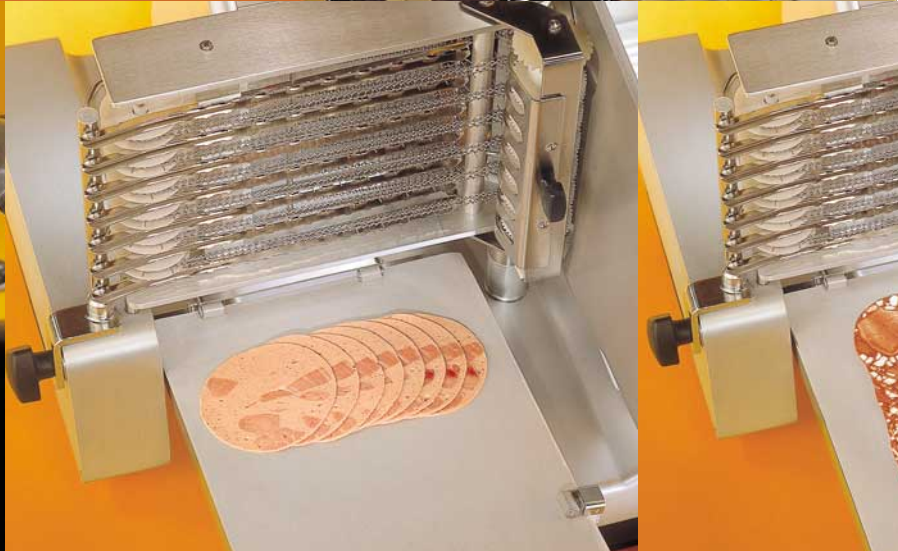
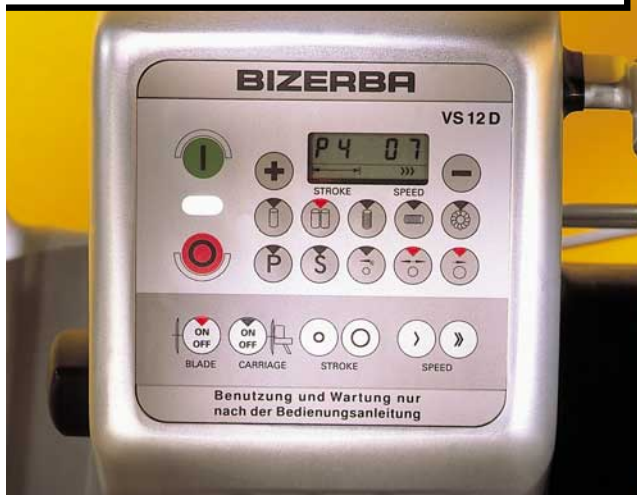





# INCREASE PRODUCTIVITY WITH STYLE!

## → Flexible operation

The VS 12 D is particularly suitable for slicing sausage, ham, bacon, smoked meats, roast meats, other meats. It works perfect in the butcher's, grocer's and baker's as well as in the delicatessen and in the kitchen. Everywhere, where highly flexible operation and decorative and appealing presentation of sliced food is required. For this, the VS 12 D offers countless presentation shapes with extensive, simple selection options as well as storing a default delivery presentation at switch-on.

## → High-tech precision

The VS 12 D cuts cleanly, safely and quickly – from the first slice to the last. Taking care of this is a powerful, low-noise blade drive together with the proven, first-class hollow-ground blade of hard chrome-plated special steel. The adjustable product support located in close proximity to the slicing position effectively prevents downward movement of the product.

## → Operation

In both automatic and manual modes, the VS 12 D offers highly-reliable operation and maximum safety. Perfect all-round protection and the low position of the carriage for easy handling enables fast and fatigue-free working. The practical Quick remnant holder retains food product remnants with its plastic spikes and therefore minimizes loss of cut ends and segments. Cutting power can be continuously adjusted. Wafer-thin slices can be cut using the extended scale in the range 0 to 3 mm. The VS 12 D is extremely rugged – it can be heavily loaded and is corrosion-free even in continuous automatic mode. Slide, stop plate, scraper and blade cover are constructed of precision anodized aluminum. Proven sliding channels guarantee clean, effortless sliding of the product to be sliced. The guides incorporated within the machine casing make for easy running of the carriage.

**\*\* WITH THE VARIED DELIVERY PROGRAMS  
YOU ARE ON THE ROAD TO SUCCESS**

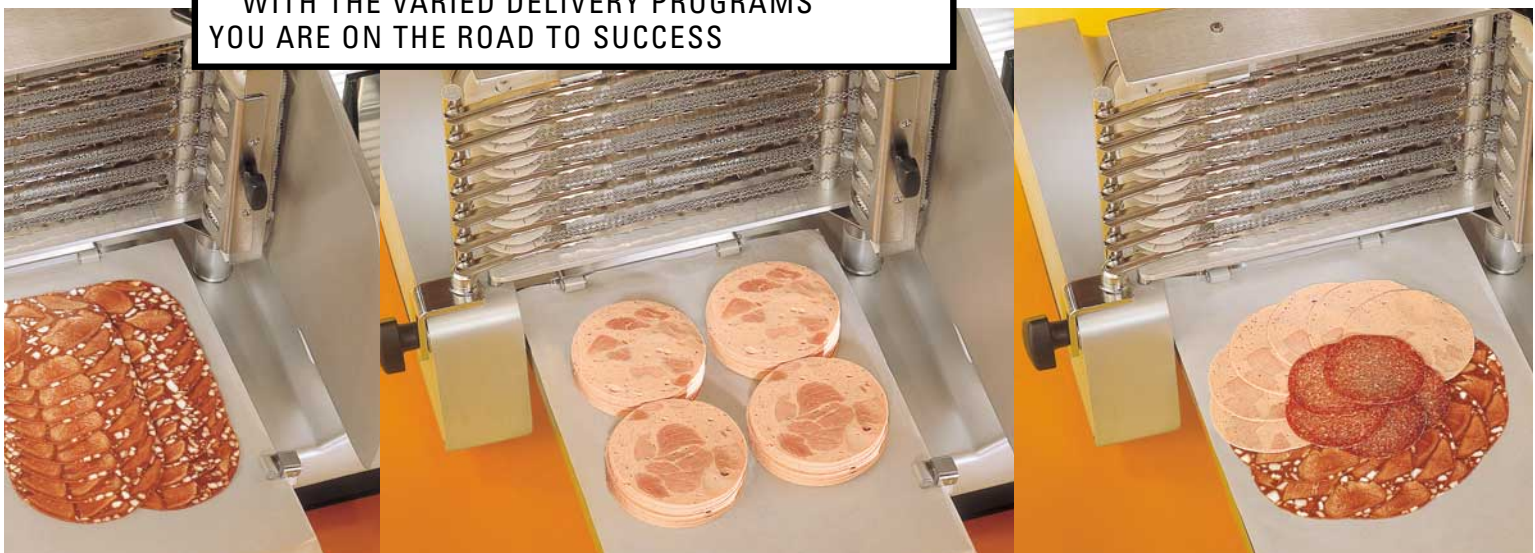

### → Presentation made easy

Varied presentation of the sliced product is one of the most important performance features of the VS 12 D. The following programs are available:

- Shingling in 3 rows, "longitudinal" and "transverse"
- Stacking with one product (maximum diameter 105 mm), up to 2 stacks one behind the other
- Double-stacking with one product up to 4 stacks adjacent and one behind the other
- Circular presentation in 3 circles onto the delivery table

The delivery program makes it easy for you:

- Permanent display of numbers of slices and portions
- Selection of numbers of slices with "+" and "-"
- Selection of number of slices in all three circular presentation modes is possible
- Storing of a sliced presentation pattern via the "SET" key

### → Accident protection

The machine has been licensed in compliance with EG Machines Guideline No. 98/37/EG for Safety and Hygiene by an accredited testing laboratory in accordance with Design Test No. 01014 and GS Test No.01015. The EG Certificate of Conformance in the operating instructions certifies compliance with the regulations.



→ DECORATIVE PRESENTATION BRINGS APPETITE FOR MORE

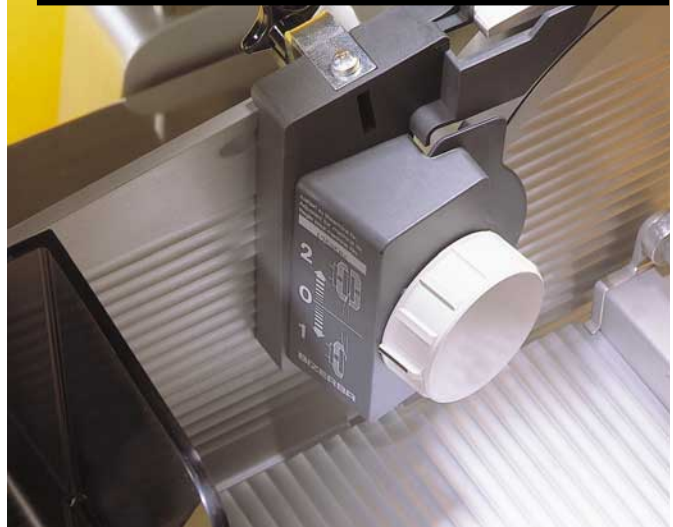

→ ROUND DELIVERY PLATTER (OPTION)





## YOU WANT FLEXIBILITY

## AND CONVENIENT OPERATION?

### → Automatic or manual – the VS 12 D leaves the choice to you

The VS 12 D is a universal precision slicing machine with particularly flexible operating possibilities: fully-automatic mode for efficient slicing in volume and manual mode for counter sales. In fully-automatic mode, with its motorized carriage drive it offers the advantage of automatically slicing and arranging the sliced goods in portions, ideal for carrying out customer orders or preparing for the weekend rush of customers. The slicing performance can be controlled via three carriage speeds and three stroke lengths. That means an individual cutting speed for every product. In manual mode, it shines through its smooth and precise sliding action and food product-holding mechanism.

Delivery of slices occurs automatically – **untouched by hand**. In both operating modes, the variety of delivery shapes is one of the crucial performance criteria of the Bizerba VS 12 D. Not to forget the particularly efficient handling and fast, easy cleaning.

### → Cleaning and maintenance

The remnant holder, blade cover and feed slide can be removed in next to no time. For easy, thorough cleaning, the carriage can be swung out at the "0" slicing setting.

Resharpener of the blade is carried out with a compact grinding device, which is installed in an instant and can be operated with ease using exactly-defined settings.



**\*\* THE VS 12 D OFFERS YOU EXACTLY THE PERFORMANCE YOU NEED RIGHT NOW: FULLY AUTOMATIC OR MANUAL**



## THE MOST IMPORTANT TECHNICAL DATA



Type of power	Voltage*)	Frequency	Nom. current consumption	Power consumption
	V	Hz	A	kW
→ Single-phase AC:	230 120	50 60	2.5 4.2	0.575 0.504
→ Three-phase AC:	230/400	50	1.9/1.38	0.552
→ Blade diameter:	330 mm (13")			
→ Blade speed:	266 rpm			
→ No. of slide strokes:	long 30-40-50	medium 35-48-58	short 60-68-75	
→ Foodstuffs aperture with delivery attachment:	min. 50 x 50 mm (1.9" x 1.9")	max. 183 x 240 mm (7.2" x 9.5")		
→ Foodstuffs aperture w/o delivery attachment:	224 x 260 mm (8.8" x 10.2")			
→ Slice thickness adjustment, continuous with delivery attachment:	0.5 to 8 mm (0.02" to 0.31")			
→ Slice thickness adjustment, continuous w/o delivery attachment:	0.5 to 24 mm (0.02" to 0.94")			
→ Dimensions mm (inches):				

→ External dimensions:	L 620 (24.4")	W 795 (31.3")	H 495 (19.5")
→ Mounting surface:	L 515 (20.3")	W 430 (16.9")	
→ Working surface:	L2 800 (31.5")	W2 980 (38.6")	
→ Stack height:	60 mm (2.4")		
→ Class of protection:	IP 33		
→ Dimensions packed:	58 x 82 x 70 cm (L x W x H) (22.8" x 32.3" x 27.6")		
→ Weight:	approx. 75 kg/165 lb (net) approx. 87 kg/191.4 lb (gross)		
→ Delivery table:	254 x 346 mm (10" x 13.6")		
→ Paper size:	1/8 sheet - 250 x 375 mm (9.8" x 14.8")		
→ Film size:	210 x 360 mm (8.3" x 14.2")		
→ Table displacement:	160 mm (6.3")		
→ Additional equipment:	Round platter for star-shaped foodstuffs presentation, Teflon-coated blade, stop plate and blade cover with non-stick coating		

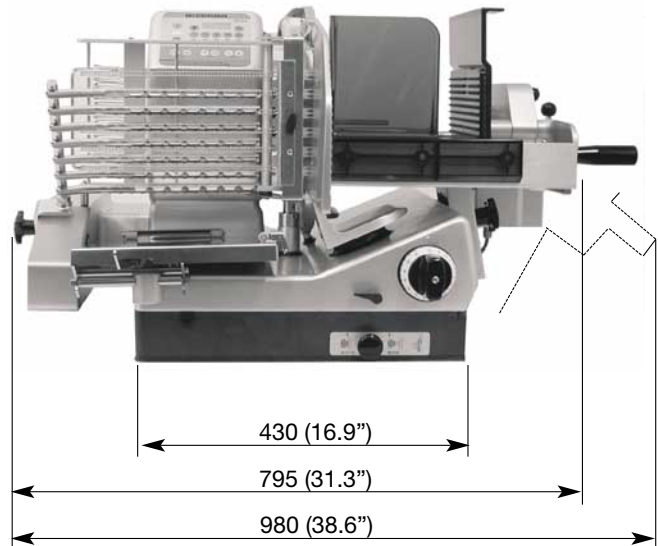
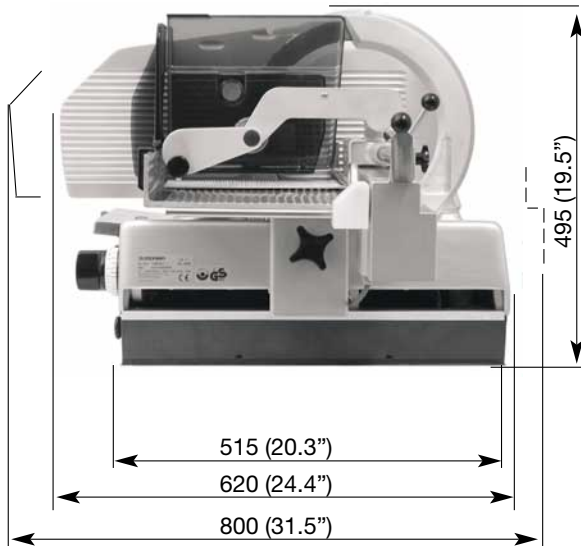

**BIZERBA**  
\_balanced information